

Simple Installation, Secure You Always.

Installation and Operating Instructions

Version 1.0

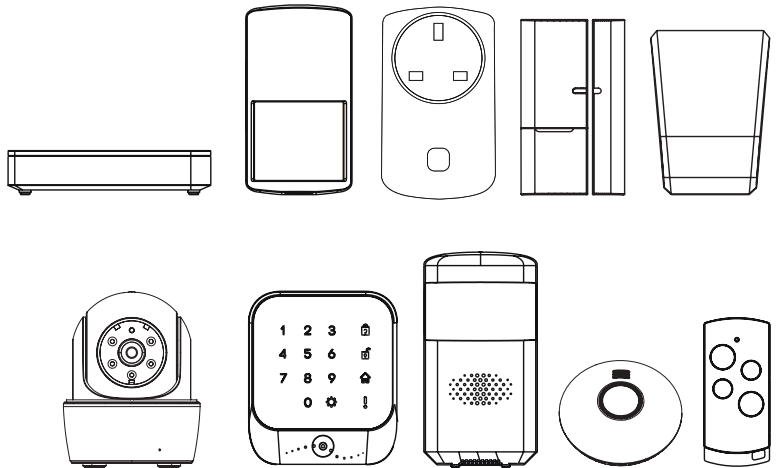

PLEASE READ THESE INSTRUCTIONS CAREFULLY BEFORE USING THIS PRODUCT
AND KEEP THIS MANUAL FOR FUTURE REFERENCE.

CONTENTS

KIT CONTENT	1
INTRODUCTION	3
Using the Power Switch sensor as a signal repeater	6
GETTING STARTED	7
Download the Android Version Ximple W2	7
Download the iOS Version Ximple W2	7
1. Connect the Main Control Unit to the Internet	7
2. Setup the Camera.....	9
3. Pairing the Motion Sensor.....	11
4. Pairing the Power Switch	12
5. Pairing the Door/Window Sensor	13
6. Pairing the Indoor Siren	14
7. Pairing the Remote Keychain.....	15
8. Pairing the Smoke Sensor	16
9. Pairing the Outdoor Siren	17
10. Pairing the RF Keypad	18
HOW TO INSTALL THE CAMERA	19
Camera Installation.....	19
HOW TO INSTALL THE SENSOR.....	20
1. Installing the Motion Sensor.....	20
2. Installing the Door/Window Sensor	21
3. Installing the Siren	22
4. Installing RF Keypad.....	23
5. Installing the Outdoor Siren	23
6. Installing the Smoke Sensor	24
APP OPERATION	25
Status Page Diagram	25
1. Status Indicator/Edit.....	25
2. Scenario	28
3. Event List.....	33
4. Setting	33
ADDITIONAL USEFUL FEATURE	39
TROUBLESHOOTING	40
FREQUENTLY ASKED QUESTION	41
PRODUCT SPECIFICATION.....	48

IMPORTANT SAFETY NOTICE

Please keep the button cell out of reach of Children. Do not place button cell in the mouth as by doing so can cause severe injuries if swallowed.

This information can help you safely use your security system. Follow and retain all information included with your system.

Customer safety is important. Our products are developed to be safe and effective. However, Main Control Unit, sensors and cameras are electronic devices. Power cords, power adapters, and other features can create potential safety risks that can result in physical injury or property damage, especially if misused. To reduce these risks, follow the instructions included with your product, observe all warnings on the product and in the operating instructions, and review the information included in this document carefully. By carefully following the information contained in this document and provided with your product, you can help protect yourself from hazards and create a safer operation environment.

Note: This information includes references to power adapters and batteries. In addition to the security kit, some products (such as additional cameras) ship with external power adapters. If you have such a product, this information applies to your product. In addition, some sensors contain a coin-sized battery that provides power to the sensors. Please keep the coin-sized battery out of reach of children. Do not place the battery in the mouth as by doing so can cause severe injuries if swallowed.

The cords and cables supplied with the system can present a potential strangulation hazard if the child pulls the cords or cables and it becomes wrapped around the neck. Please make sure cords and cables are placed out of reach of the children.

Conditions that require immediate action

Products can become damaged due to misuse or neglect. Some product damage is serious enough that the product should not be used again until it has been inspected and, if necessary, repaired by an authorized servicer.

As with any electronic device, pay close attention to the product when it is turned on. On very rare occasions, you might notice an odor or see a puff of smoke or sparks vent from your product. Or you might hear sounds like popping, cracking or hissing. These conditions might merely mean that an internal electronic component has failed in a safe and controlled manner. Or, they might indicate a potential safety issue. However, do not take risks or attempt to diagnose the situation yourself. Contact the Customer Support Center for further guidance.

Frequently inspect your security system and its components for damage or wear or signs of danger. If you have any question about the condition of a component, do not use the product. Contact the Customer Support Center or the product supplier for instructions on how to inspect the product and have it repaired, if necessary.

In the unlikely event that you notice any of the following conditions, or if you have any safety concerns with your product, stop using the product and unplug it from the power source and telecommunication lines until you can speak to the Customer Support Center for further guidance.

- Power cords, plugs, power adapters, extension cords, surge protectors, or power supplies that are cracked, broken, or damaged.
- Signs of overheating, smoke, sparks, or fire.
- Damage to a battery (such as cracks, dents, or creases), discharge from a battery, or a buildup of foreign substances on the battery.
- A cracking, hissing or popping sound, or strong odor that comes from the product.
- Signs that liquid has been spilled or an object has fallen onto the Main Control Unit, sensor and camera, and the power cord or power adapter.
- The Main Control Unit, sensor, camera, power cord, or power adapter has been exposed to water.
- The product has been dropped or damaged in any way.
- The product does not operate normally when you follow the operating instructions.

Note: If you notice these conditions with a product, stop using that product until you can contact the product supplier for further instructions.

WARNINGS

This product is not designed or approved for use on powerlines other than 100-240VAC, 50Hz or 60Hz, single phase.

Attempting to use this product on non-approved powerlines may have hazardous consequences.



FCC Compliance Statement: This device complies with Part 15 of the FCC rules. Operation is subjected to the following two conditions: (1) this device may not cause harmful interference, and (2) this device must accept any interference received, including interference that may cause undesired operation.



Products with CE Marking comply with EMC Directive (2014/30/EU); Low Voltage Directive (2014/35/EU); RED (2014/53/EU); ROHS Directive (2011/65/EU) issued by the Commission of the European Community. Compliance with these directives implies conformity to the following European Norms:
EMC: EN 301 489
LVD: EN 60950
Radio: EN 300 328

FCC/CE WARNING

This equipment has been tested and found to comply with limits for a Class B digital device, pursuant to Part 15 of the FCC rules and ETSI(EN) 300328. These limits are designed to provide reasonable protection against harmful interference in residential installations. This equipment generates, uses, and can radiate radio frequency energy, and if not installed and used in accordance with the instructions, may cause harmful interference to radio communications. However, there is no guarantee that interference will not occur in a particular installation. If this equipment does interference to radio or television equipment reception, which can be determined by turning the equipment off and on, the user is encouraged to try to correct the interference by one or more of the following measures:

- Reorient or relocate the receiving antenna.
- Move the equipment away from the receiver.
- Plug the equipment into an outlet on a circuit different from that to which the receiver is connected.
- Consult the dealer or an experienced radio/television technician for additional suggestions.

You are cautioned that any change or modifications to the equipment not expressly approved by the party responsible for compliance could void your authority to operate such equipment.

DISPOSAL



If the camera system no longer functions or can no longer be repaired, it must be disposed of according to the valid statutory regulations.

Disposal of spent batteries/accumulators:

You are required by law (Battery Ordinance) to return all spent batteries and accumulators. Disposing of spent batteries/accumulators with common household waste is prohibited! Batteries/accumulators that contain hazardous substances are marked with the symbols on the side. These symbols indicate that it is prohibited to dispose of these batteries/accumulators in the household waste. The abbreviations for the respective heavy metals are: Cd=cadmium, Hg=mercury, Pb=lead. You can return spent batteries and accumulators that can no longer be charged to the designated collection points in your community, outlets or wherever batteries or accumulators are sold. Following these instructions will allow you to fulfill the legal requirements and contribute to the protection of our environment!

KIT CONTENT



DO NOT REMOVE THE INSULATING PLASTIC on the sensors. It will activate the pairing process. Please follow the sections below for easy installation.

If you have already removed the insulating plastic tab, please refer to the section "If you need to pair the sensor again:" to add sensor(s) to the system.

Main Control Unit

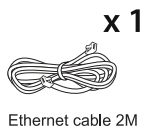
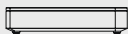

Door/Window Sensor

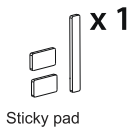
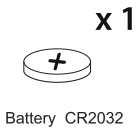



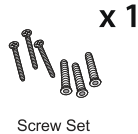
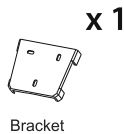
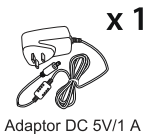
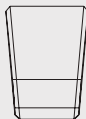



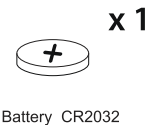





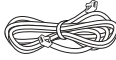



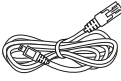







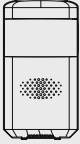
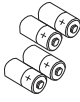

Indoor Siren



Remote Keychain





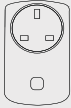



OPTIONAL ACCESSORIES

<p>Indoor Camera</p> 	<p>x 1  x 1  x 1  x 1 </p> <p>Adaptor DC 5V/1.5A Ethernet cable 2M Camera Stant Camera Antenna</p>
<p>Outdoor Camera</p> 	<p>x 1  x 1  x 1  x 1 </p> <p>Adaptor DC 5V/1.5A USB to RJ-45 Connector Cable 300 mm Camera Stand Camera Antenna</p>
<p>Motion PIR</p> 	<p>x 3  x 1  x 1  x 1 </p> <p>Battery AA 1.5V Sticky pad Screw Set Bracket</p>
<p>Outdoor Siren</p> 	<p>x 4  x 1  x 1 </p> <p>Battery D 1.5V Wall Bracket Screw Set</p>
<p>Smoke Sensor</p> 	<p>x 2  x 1  x 1 </p> <p>Battery AA 1.5V Bracket Screw Set</p>
<p>RF Keypad</p> 	<p>x 4  x 1  x 1  x 2 </p> <p>Battery AA 1.5V Wall Bracket Screw Set RF Tags</p>
<p>Power Switch</p> 	<p>N/A</p>

INTRODUCTION

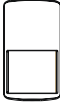
The Ximple W2 is an expendable and extendable security system that combines power management to make your live more secure and energy efficient. You can scale up the coverage at anytime by implementing additional sensor(s) and/or camera(s).

You can easily access the system from anywhere in the world via internet. The Ximple W2 iOS/Android app allows you to view/record video, turn power switch on/off, activate/deactivate siren manually or automatically. You can also create various scenarios to allow the system to automatically respond to the situation even when you are not at home/office.

Product Name	Function
Main Control Panel 	The central control of the Ximple W2 system. It provides communication for remote access, sensors and mobile devices. Main Control Unit can send out push notification and Email when sensor(s) is triggered.
Indoor Camera 	Offers day/night on-site/remote live-view (visual verification) and video recording and storage. The camera also has dual-layer motion detection consist of hardware PIR sensor and embedded video image analyzer for maximum protection.
Motion PIR 	Built for larger area detection, such as living room or entrance. Once detects motion, the motion PIR can alert system and activate Power Switch (turning on light), Siren (alert sound) and Camera (view/record). Note: To conserve battery power, the Motion Sensor will be temporarily deactivated for 2 mins after every trigger event. This is also good for controlling the unnecessary push notifications receiving on your mobile device.
Power Switch 	The Power Switch can be controlled via app (On/Off), Door/Window Sensor (trigger on), PIR (trigger on) and Remote Keychain (preset on). The Power Switch can also act as repeater to extend the service range for one single device, such as Power Switch and Indoor Siren.
Door/Window Sensor 	Installed on the door/window. After system is armed the Door/Window Sensor can alert system the door/window has been repositioned and activate Power Switch (turning on light), Siren (alert sound) and Camera (view/record).
Indoor Siren 	The Siren can be controlled via Ximple W2 App and Remote Keychain (activate/deactivate) or triggered by other devices such as Camera, Door/Window Sensor and Motion Sensor.
Remote Keychain 	You can use Remote Keychain to ARM/DISARM system, activate camera recording function and set off siren. You can predefine which sensor(s) to work with the Remote Keychain. The control of the Remote Keychain correlate with app's On-Touch-Scenario.

Product Name

Function

Outdoor Siren

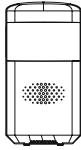

The Outdoor Siren can be controlled via Ximple W2 app and Remote Keychain (activate/deactivate) or triggered by other devices such as Ximple W2 Camera, Door/Window Sensor and Motion Sensor.

Smoke Sensor



Detects the smoke generated from fire. The Smoke Sensor is always armed and will alert user by its built-in siren, further by informing the system abnormal situation is happening so system can send out push notifications to user(s) and carry out preset functions. Besides being a part of the Ximple W2 system, the Smoke Sensor can function as a standalone device as well.

RF Keypad



RF Keypad - The RF Keypad is for wall-mount near the entrance for System Arm/Part-Arm/Disarm, either manually or via its RF Tag. The RF Keypad can also activate the Panic function for Ximple W2 Camera to record, Lights on and Indoor/Outdoor Siren sound off by one touch.

Note: Maintenance Function, Disabling the system alarm when release the tamper button (battery change).

Steps: Program mode > enter security code > Press "9" > remove keypad from the wall bracket> change battery > remount the keypad.

The diagram below shows the suggested location(s) for Ximple W2. Use this as a guide for your installation. The system is extendable and expandable with additional compatible Wireless Camera, motion sensors, door/window sensor, siren or other sensors (not included in this product kit) for greater protection.

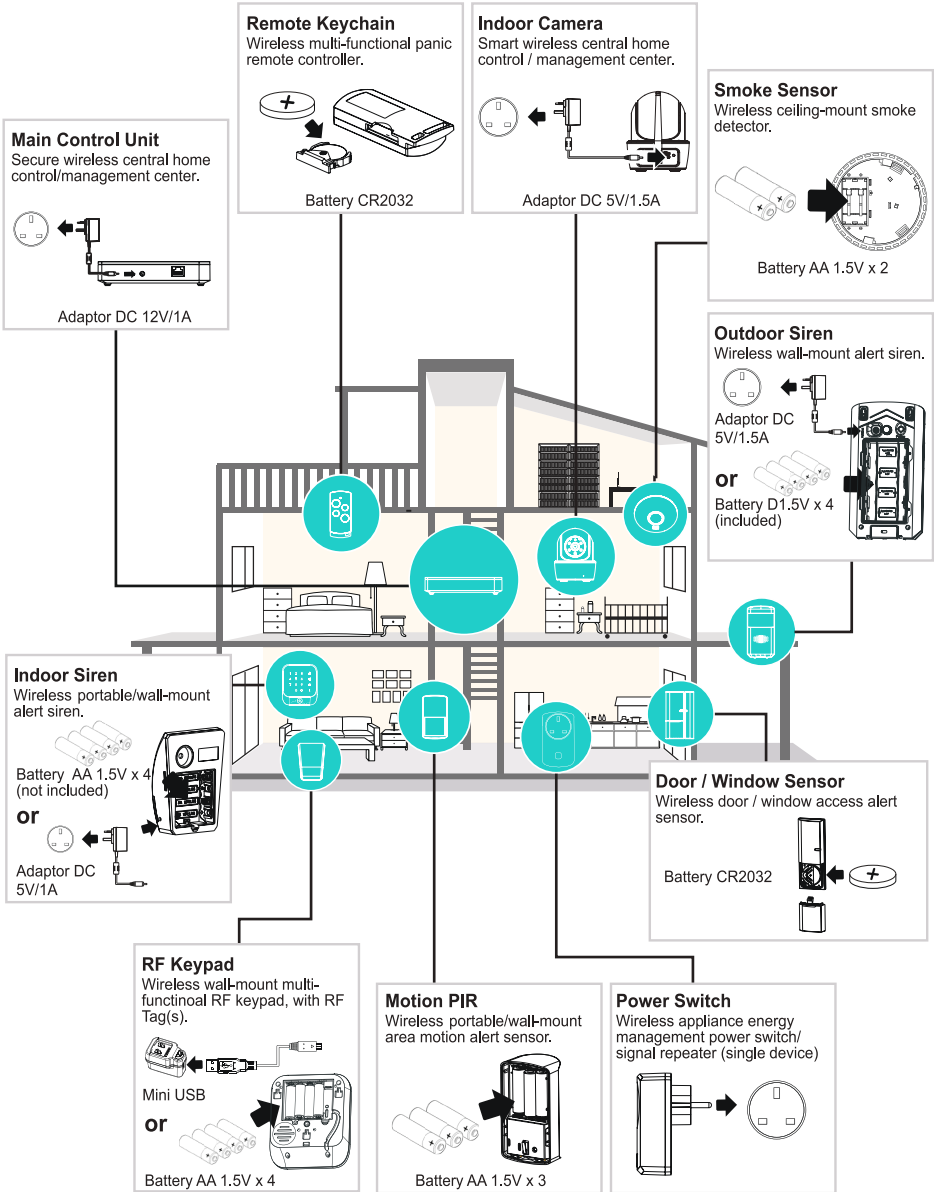

Using the Power Switch sensor as a signal repeater

In some cases, pre-existing environmental factors may affect the performance of the wireless communication between the Main Control Unit and sensors, such as:

- Numbers of walls between the Main Control Unit and the sensor(s)
- Materials of the building structure
- Interference from unknown source

When encountering such situation, you can use the Power Switch as signal repeater improve the wireless transmission service range.

Please note that at any given time, after successful setup, the Power Switch repeater function can extend the communication for one single sensor, such as Motion Sensor, Power Switch, Siren and Door/Window Sensor. The Power Switch will still obtain its original On/Off function after the repeater function has been activated.

To establish the repeater function, additional between the Power Switch (repeater) and the end Sensor will be required.

For best performance, the Power Switch (repeater) should have direct sight with the end sensor, without any wall/obstructive objects in between.

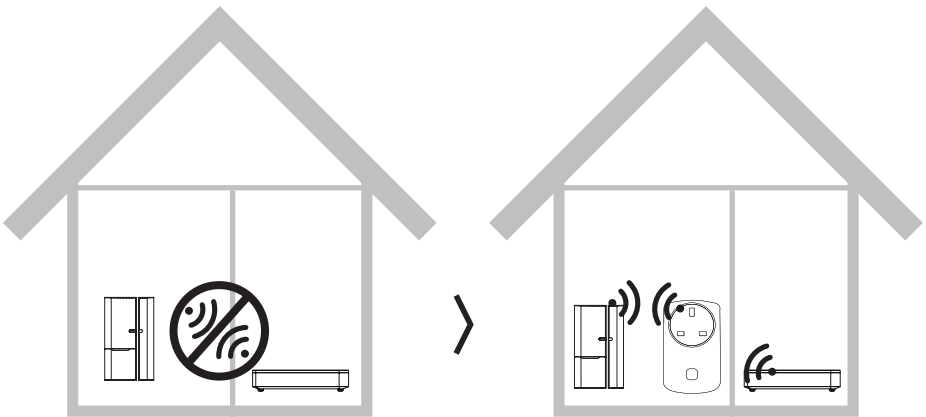

Please follow the procedures in the 'Repeater Setup' section to complete the process.

GETTING STARTED

The sensor(s) require to have sufficient battery power enable for successful pairing process and normal operation afterwards. If you cannot pair the sensor(s) to Main Control Unit or operate control command, please first replace the battery supplied with new one to resolve the issue.

Please make sure your mobile device is connected to the local WiFi through out the whole setup & pairings.

Download the Android Version Ximple W2 App

Please go to the Google Play to search for 'Ximple W2' and install the app to your mobile device.



Download the iOS Version Ximple W2 App

Please go to the Apple App Store to search for 'Ximple W2' and install the app to your mobile device.



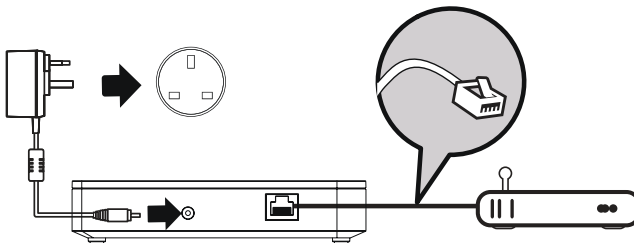

1. Connect the Main Control Unit to the Internet

- (1) First connect the Main Control Unit to Wi-Fi router via the Ethernet cable supplied, then power on the Main Control Unit by using the power adaptor supplied .

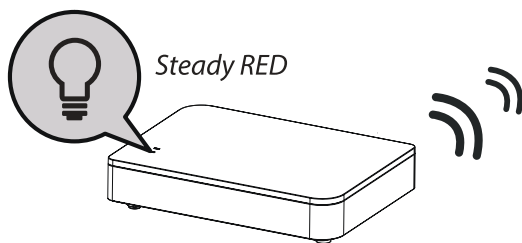

- (2) The RED LED indicator will light up and beep once to indicate successful power up. Seconds later the Main Control Unit will again beep twice to indicate the Main Control Unit is ready for setup via the 'Ximple W2' app.



- (3) Launch the 'Ximple W2' app. The app will first search for the Main Control Unit connecting to the home Wi-Fi router and retrieve the Main Control Unit DID automatically. Please assign the Main Control Unit with preferred System Name and enter Default Security Code '123456', tap  to complete the Main Control Unit setup. If the Main Control DID/Security Code cannot be retrieved, please check to make sure the Main Control Unit is powered on and the Ethernet cable is securely connected to the Wi-Fi router.

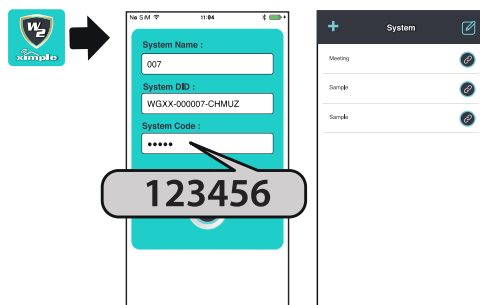

The newly added Main Control Unit will now appear and you can tap it to enter the system and continue with setup for camera(s), sensor(s), switch(es) and remote controller.

Note:

- (1) The Main Control Unit should be powered on and connected to the Wi-Fi router at all time.
- (2) Should need to enter the Main Control Unit DID/Security Code manually, the DID information is located at the bottom of the Main Control Unit and the Security Code by default is '123456'.

You can now continue with setup for camera(s), sensor(s) and remote keychain.

2. Setup the Camera

Note: You can ONLY setup using camera(s) specified compatibility with the system, also, if you have previously purchased and installed compatible camera(s), you will only need to complete steps (3) and (4) for your existing camera to work with the new system.

- (1) First connect the camera to the Wi-Fi router via the Ethernet cable supplied.
- (2) Power on the camera via the power adaptor supplied and wait until for both RED (power indicator) /GREEN (linkage indicator) indicators become steady on.

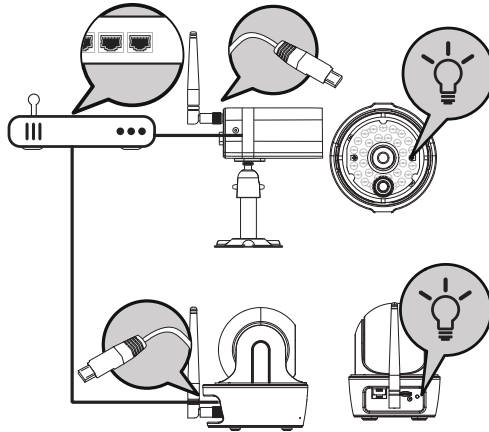

Note: DO NOT begin the APP setup process until both LEDs become steady on.

- (3) Using 'Ximple W2', tap **+** in the 'Status' section and choose  to add new camera to the Main Control unit. The app will now search for the camera connecting to the router and pull in the camera DID.

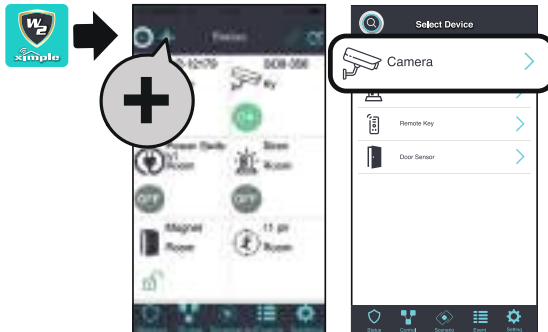



- (4) Please now name your camera and specify the location of where the camera will be installed. The camera default Security Code is '123456' (previously installed camera may have been assigned with different security code). Tap 'Save' to complete pairing the camera to the Main Control Unit.

Note:

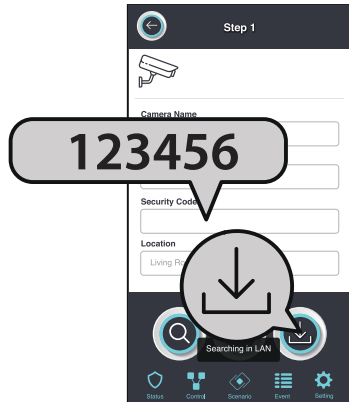
- (1) The app will first search for the available camera connected to the Wi-Fi router.
- (2) If the camera cannot be found, please first check to make sure the camera is powered on and the Ethernet cable is securely connected to the Wi-Fi router.
- (3) You can always enter the camera DID/ password manually. The camera DID is located on the camera and the password by default is '123456'.



- (5) If you prefer using Ethernet cable, you can now swap out the cable supplied with your own. For wireless connection/operation please follow steps below.
- (6) For camera to work wirelessly with Main Control Unit, you will need to add router to app: Go to , tap  on upper right and select  to enter camera info.





In camera info section, tap  and enter camera password (default: 123456) to enter Advanced Settings. In Wi-Fi setting section, choose the router and enter its password. Camera will automatically reboot, you must now remove the Ethernet cable. Please wait until both LED's on camera become steady on around 90 seconds. The camera can now operate wirelessly.



Verifying the Setup

Go to Status and your new camera should be ON, tap it once to see live view.

3. Pair the Motion Sensor

- (1) Using 'Ximple W2', tap  in the 'Status' section.
- (2) Choose 'Motion Sensor' and  to initiate the pairing process.

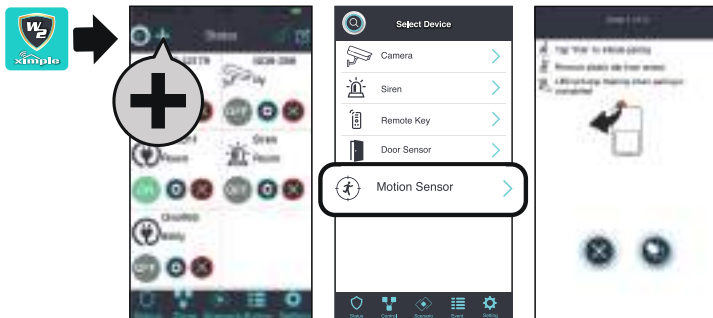

(3A) Auto Pairing Method

Remove the insulating plastic tab to send out the pairing signal.

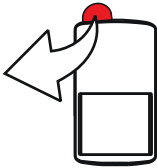

(3B) Manual Pairing Method

Press the **'Pairing'** button located inside the battery compartment.

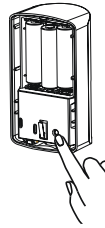

(4) Enter **'Device Name'** and **'Location'**, tap **'Save'** to complete the pairing process. The newly paired sensor will now display in the app's **'Status'** section.

Verifying the Setup

After complete pairing, face the motion sensor to wall where no movement can be detected, wait for few minutes for the sensor to complete condition analysis. Wave your hand in front of the sensor and alert indicator should appear next to the motion sensor section on the status page of the app.

Note: To conserve battery power, the Motion Sensor will be temporarily deactivated for 2 mins after every trigger event. This is also good for controlling the unnecessary push notifications receiving on your mobile device.

4. Pairing the Power Switch

(1) Using **'Ximple W2'**, tap **+** in the **'Status'** section.

(2) Choose **'Power Switch'** and  to initiate the pairing process.

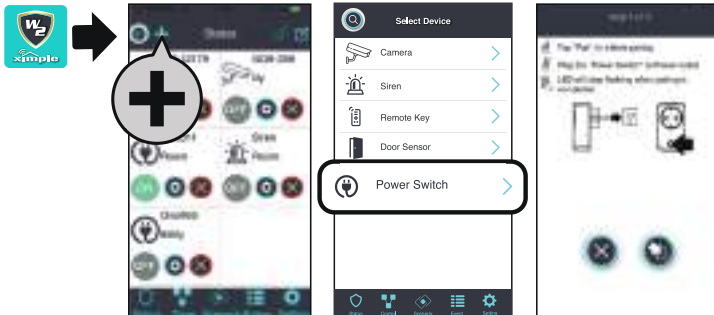

(3A) Auto Pairing Method

Plug the power switch to the outlet.
The LED will flash, indicating the power switch is sending out the pairing signal.
When the power switch is successfully paired, it will appear on the Status page of APP.

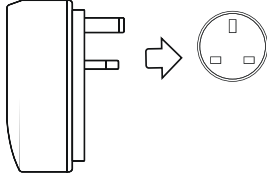

(3B) Manual Pairing Method

Press and hold the button located in the front of the Power Switch until the blue LED begin flashing.

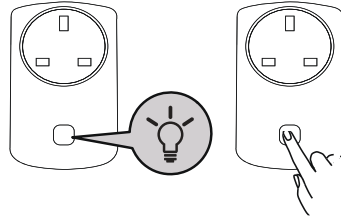

(4) Enter '**Device Name**' and '**Location**', tap '**Save**' to complete the pairing process. The newly paired switch will now display in the app's '**Status**' section.

Verifying the Setup

After complete pairing, with power switch plugged into the electrical outlet and connect light fixture to the switch. If the light fixture or any other device has its own power switch, please keep it to '**On**' position. Tap the power switch icon on the status page to turn light on and off.

Note: The power switch can also double as '**Repeater**'. This function is for advanced user. For details, please refer to Power Switch/Repeater section of the owner's manual.

5. Pairing the Door/Window Sensor

(1) Using '**Ximple W2**', tap **+** in the '**Status**' section.

(2) Choose '**Door Sensor**' and  to initiate the pairing process.

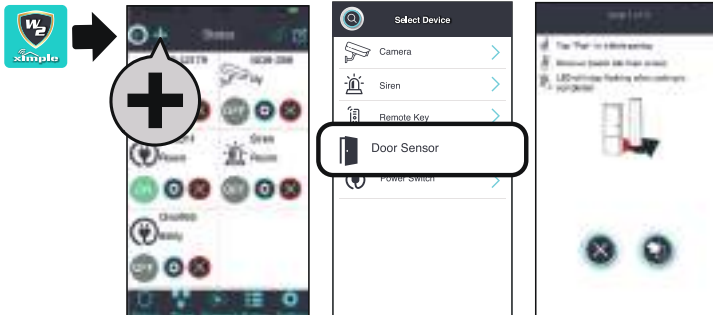

(3A) Auto Pairing Method

Remove the insulating plastic tab to send out the pairing signal.

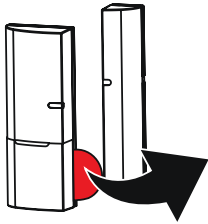

(3B) Manual Pairing Method

Remove and reinstate the battery cover.



(4) Enter '**Device Name**' and '**Location**', tap '**Save**' to complete the pairing process. The newly paired sensor will now display in the app's '**Status**' section.

Verifying the Setup

After complete pairing, separate the sensor and alert indicator should appear next to the door/window sensor section on the status page of the app.

6. Pairing the Indoor Siren

(1) Using '**Ximple W2**', tap **+** in the '**Status**' section.

(2) Choose '**Siren**' and  to initiate the pairing process.

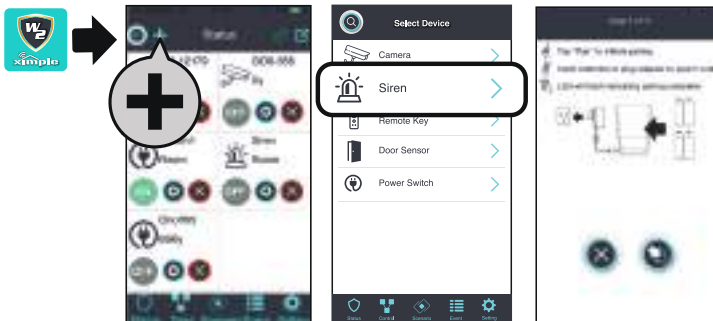

(3A) Auto Pairing Method

Enable for the Indoor Siren to send out pairing signal, either by removing the insulating plastic tab or supply power using the adaptor supplied.

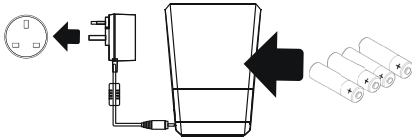

(3B) Manual Pairing Method

Press the 'Pairing' button located inside the battery compartment. Please make sure the Indoor Siren has batteries inserted or connected to the electrical outlet via the adaptor supplied.

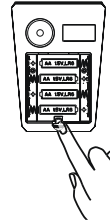

(4) Enter '**Device Name**' and '**Location**', tap '**Save**' to complete the pairing process. The newly paired sensor will now display in the app's '**Status**' section.

Verifying the Setup

From the '**Status**' section, tap the Siren icon and turn the Siren's alert sound On and Off.

7. Pairing the Remote Keychain

(1) Using '**Ximple W2**', tap **+** in the '**Status**' section.

(2) Choose '**Remote keychain**' and  to initiate the pairing process.

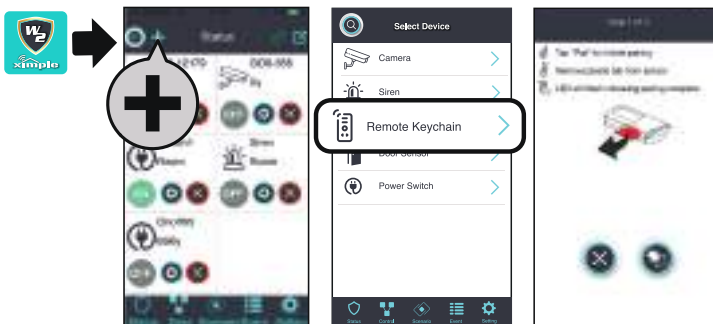

(3A) Auto Pairing Method

Remove the insulating plastic tab to send out the pairing signal.

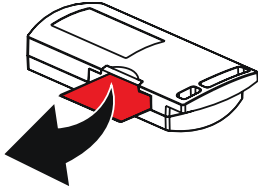

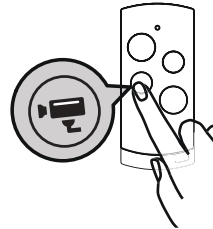

(3B) Manual Pairing Method

Press and hold the **'Camera'** button located in the front of the Remote Keychain until the blue LED begin flashing



Verifying the Setup

- ✓ Press the **'Disarm'** button  the Main Control Unit will beep once indicating the system has been disarmed.
- ✓ Press the **'Arm'** button  the Main Control Unit will beep twice and 30 seconds 'Countdown' pop-up will appear, select 'Disarm' to deactivate system arming.

8. Pairing the Smoke Sensor

(1) Launch the **'Ximple W2'** APP. Click the **+** icon.

(2) Choose **'Smoke Sensor'** and  to initiate the pairing process.

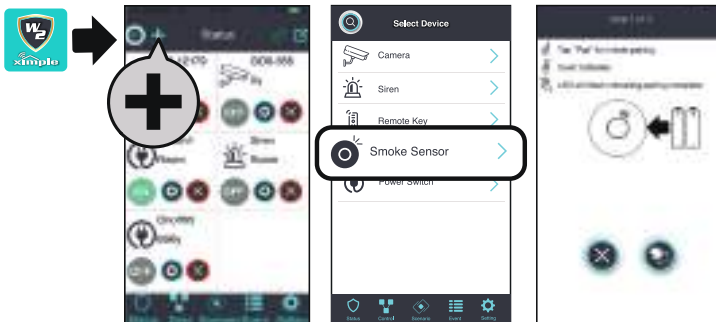

- (3) Insert the batteries supplied to power on the unit and it will automatically send out pairing signal.

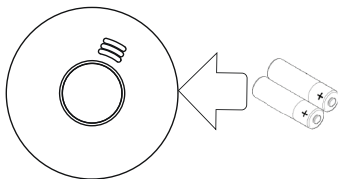

If pairing process is unsuccessful, please repeat step 1 and 2.

Verifying the setup

After complete pairing, press the "test" key on the sensor, the sensor will go off for few seconds and alert indicator should appear next to the smoke sensor section on the status page of the app.

9. Pairing the Outdoor Siren

- (1) Launch the 'Ximple W2' APP. Click the **+** icon .
- (2) Choose 'Outdoor Siren' and  to initiate the pairing process.

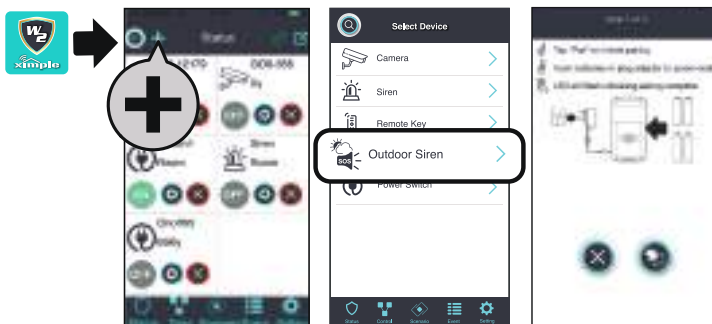

- (3) Remove the insulating plastic to send out the pairing signal. If pairing process is unsuccessful, please repeat step 1 and 2.

Verifying the setup

After complete the pairing, go to the 'status' to tap 'on' to activate siren. Tap 'off' to deactivate the siren.

10. Pairing the RF Keypad

- (1) Launch the 'Ximple W2' APP. Click the **+** icon.
- (2) Choose 'Pairing the RF Keypad' and  to initiate the pairing process.

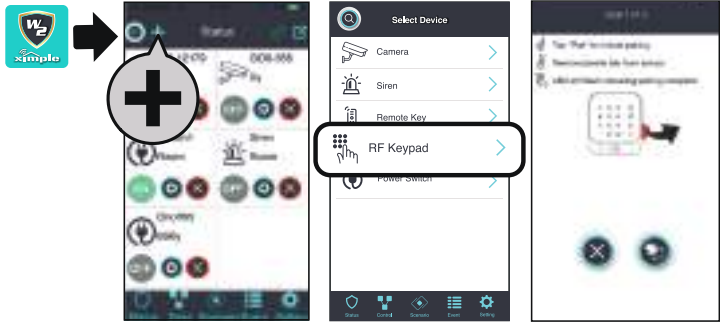

- (3) Remove the insulating plastic to send out the pairing signal.

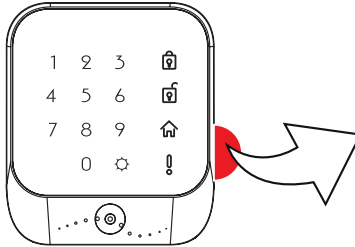

For manual pairing method, please refer to the user manual for more details.

Note: Maintenance Function, Disabling the system alarm when release the tamper button (battery change).

Steps: Program mode > enter security code > Press "9" > remove keypad from the wall bracket> change battery > remount the keypad.

Verifying the setup

Press the 'Disarm' button  , the Main Control Unit will beep once.

HOW TO INSTALL THE CAMERA

SAFETY AND INSTALLATION TIPS

Do not attempt to open the units with the power adaptor plug connected to avoid any risk of personal injury.

When installing CCTV camera(s), always follow manufacturer's advice when using power tools, steps, ladders, etc. and wear suitable protective equipment (e.g. safety goggles) when drilling holes. Before drilling holes through walls, check for hidden electricity cables and water pipes. The use of cable/pipe detector is advisable.

To prevent a fire or electrical shock hazard, do not attempt to open the housing while the unit is exposed to water or wet conditions. There are no user serviceable parts inside. Refer servicing to qualified service personnel. Avoid pointing the camera(s) directly at the sun or any moving objects that might unnecessarily cause the camera to record.

Camera Installation

- (1) Secure the camera stand on the stable surface.
- (2) Mount the camera into camera stand. Adjust the viewing angle and fix the camera tightly.

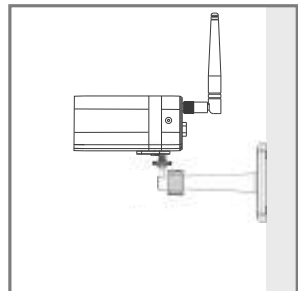
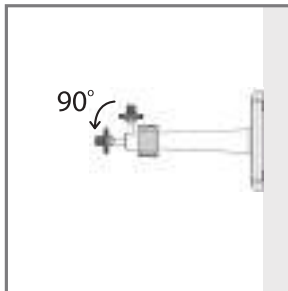
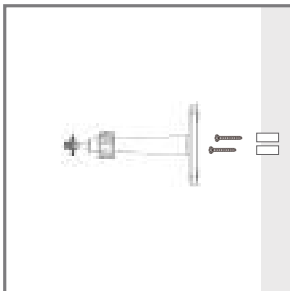

HOW TO INSTALL THE SENSOR

1. Installing the Motion Sensor

Use the double-sided tape to fix the motion sensor, or use the wall mount screws to fix the device or supplied bracket onto the wall.

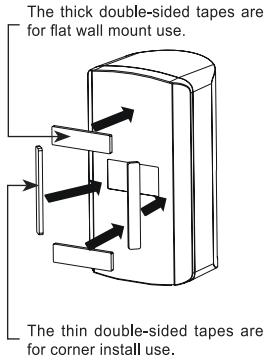

Mounting Option A

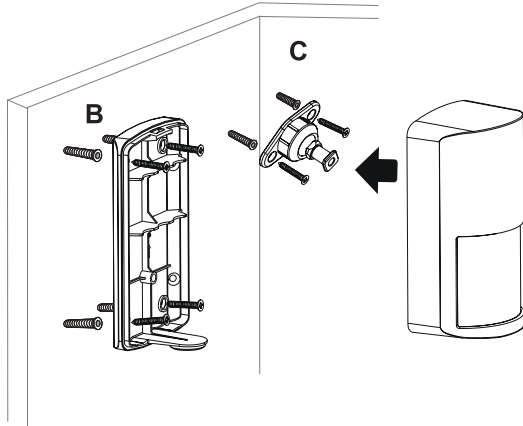

Mounting Option B/C

Please read the following items before installation to ensure maximum coverage of a monitored area.

- (1) The Motion Sensor is most effective in areas such as hallways and entry points where intruders may likely passing through.
- (2) The Motion Sensor monitors movements up to 16 meters away, with 110 degrees detection angle. Make sure the Motion Sensor is angled facing with the least obstructions for best coverage.
- (3) It is recommended to place the Motion Sensor in the corner of the room and between 2-2.5 meters from the floor.

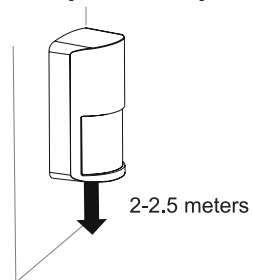
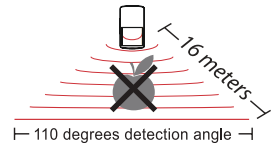

2. Installing the Door/Window Sensor

Mounting Option A - Double-Sided Tapes

- (1) Apply the double-sided tape to the backs of the Door/Window sensor.

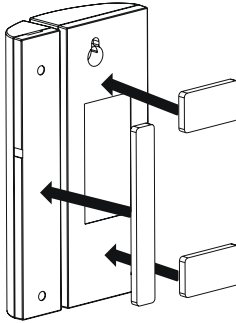

- (2) Select a location on the door/window. The large piece of the sensor should be fixed on the immovable frame of the door/window.

Align the small piece to the large one. Fix the small piece on the movable part of the door/window frame.

- (3) When it is finished, open the door or window to test if the sensor has been correctly installed. You'll receive an alert from the mobile device if the APP and sensor have been corrected installed.

Mounting Option B - Mounting Screws

- (1) Fix the first mounting screw directly onto the door/window frame (A). Place (hang) the larger piece on to the mounted screw, remove the battery compartment cover to fix the second mounting screw (B).
- (2) Open back cover of the small piece. Use the mounting screws to fix the back cover on the movable part of the door/window frame (C). Mount the sensor onto the back cover.
- (3) When it is finished, open the door or window to test if the sensor has been correctly installed. You'll receive an alert from the mobile device if the APP and sensor have been corrected installed.

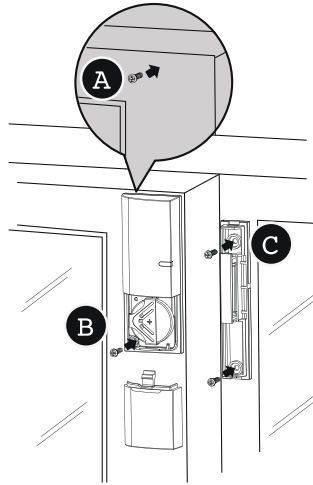

3. Installing the Siren

It is recommended to install the siren in a highly visible location with minimum obstacles near-by for maximum visual/sound alert.

A/C power option is available therefore please select suitable installation location with reachable electrical outlet.

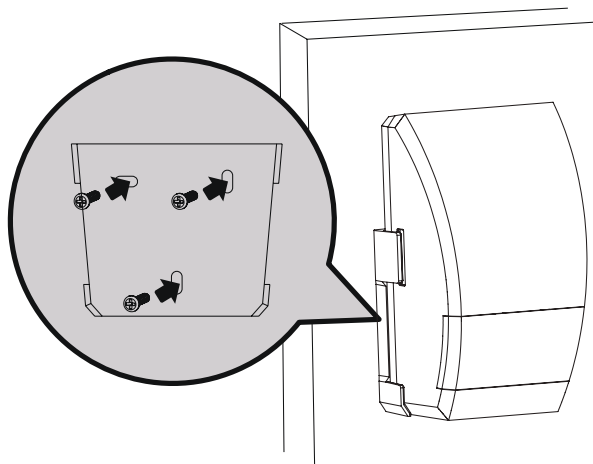

4.Installing RF Keypad

- (1) Mount the wall bracket onto a flat surfaced wall via the screw set supplied.
- (2) With batteries inserted or mini-USB power adaptor (not including) plugged into the keypad's rear power connector, secure the keypad onto the wall bracket.

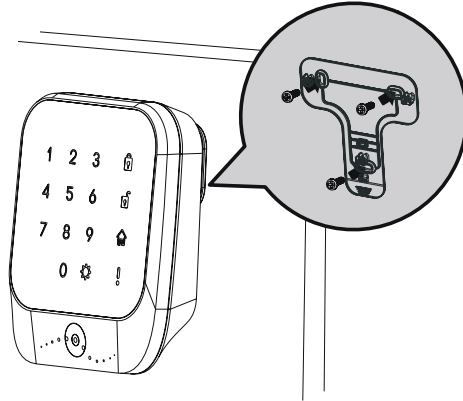

5.Installing the Outdoor Siren

- (1) First fix the mounting screws and secure bracket to the wall via the screw set supplied.
- (2) With batteries inserted or adaptor (5V/1.5A, not included) plugged into the siren rear power connector, secure the siren onto the wall.

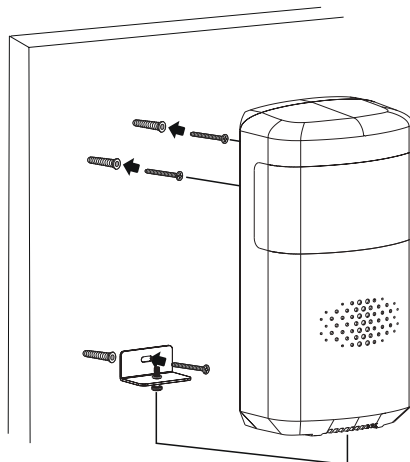

6. Installing the Smoke Sensor

- (1) First fix the mounting screws and secure the bracket to the ceiling via the screw set supplied.
- (2) With batteries inserted, secure the sensor onto the bracket.

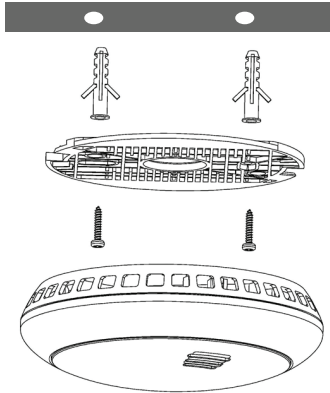

APP OPERATION

Upon selecting the Main Control Unit you will enter 'Status' section. In this section you can have an overview of all the cameras/sensors connected to the system and the real-time status of each, also you can carry out many important functions, such as arm/part-arm/disarm system, add/edit devices, view live-feed from cameras, control power switches, activate sirens. You can also navigate to other sections of the app by using the navigation bar.

Status Page Diagram

Main Control Unit Selection Section.
Tap on the Main Control Unit preferred to enter.

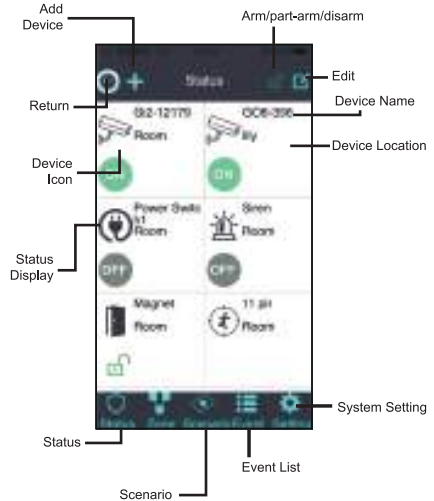
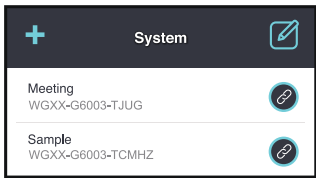

1. Status Indicator / Edit

The app displays device status using sharp contrast icons so you can clearly interpret and react to the situation/event.



Status



Status Indicator		Door/Window Close
		Door/Window Open
		Sensor On
		Sensor Off
		Sensor Triggered
		Power Low
Edit Icon		Delete
		Edit Mode

Tap 'Edit' to enter Edit Mode and select the device. You can alter the name and location information, besides, for Power Switch you can setup Auto OFF timer (only effective for Scenario) and for Door/Window Sensor you can setup Entry Delay Time so after system armed the contact will not set off the system for 30 seconds. The user will then have 30 seconds to disarm the system.



Control Camera

Tap on camera icon for live-view and control camera/sensor(s)

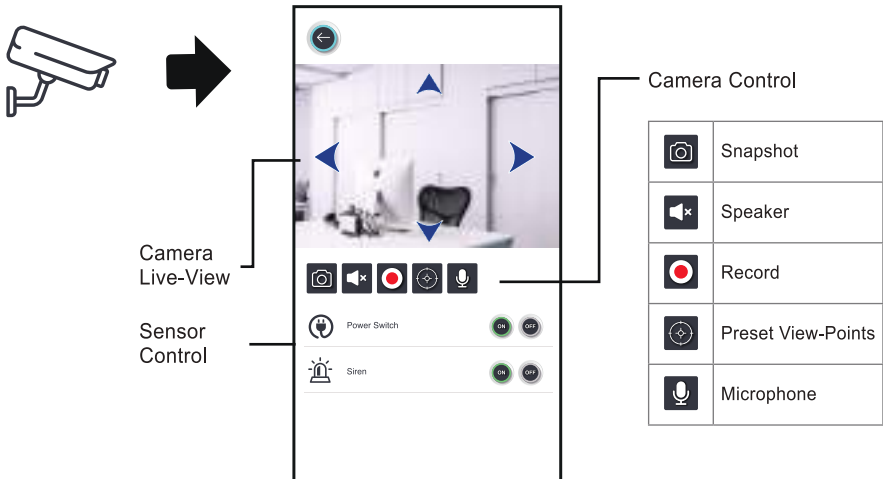

Control Power Switch

1. Tap on Power Switch icon to control selected Power Switch
2. Tap on 'On' or 'Off' to turn Power Switch on or off



Control Indoor/Outdoor Siren



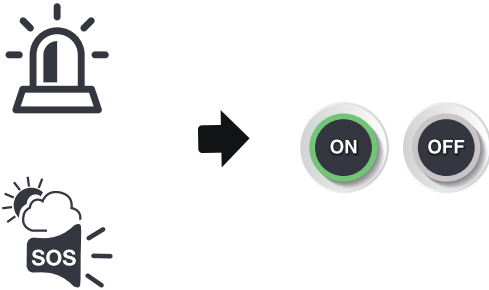

1. Tap on Siren Icon to control selected Siren
2. Tap on 'On' or 'Off' to turn siren's alert sound on or off

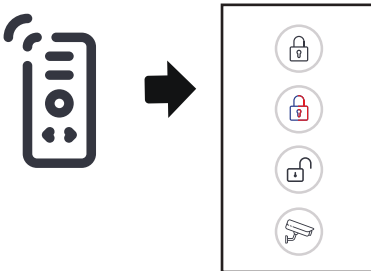

Control Remote Keychain

Tap on Remote Keychain Icon to activate in-app Remote Keychain



	System Arm
	System Disarm
	System Part-Arm
	Camera Record
	Panic

See '**Scenario**' section for more details

Control RF Keypad

Tap on RF Keypad Icon to activate in-app control

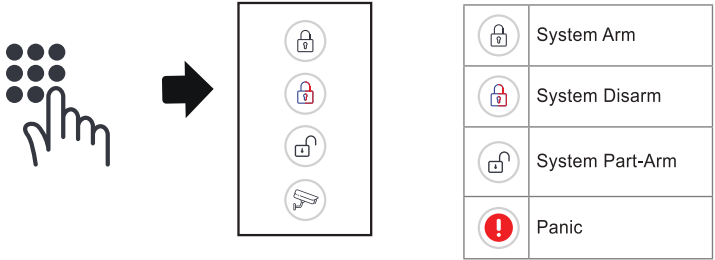

2. Scenario



Scenario

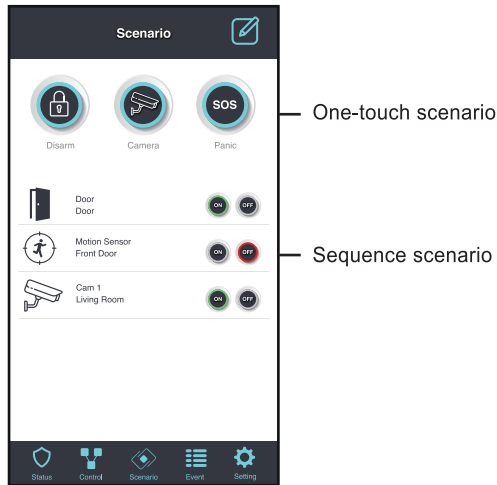

Both the '**One-touch Scenario**' and the '**Sequence Scenario**' are designed for system to carry out customized security functions after setup, such as activate single/multiple cameras and sensors for recording and alert. You can configure your own but just be reminded to "save" the settings.

One-touch Scenario

Allowing you to conveniently activate the preset security scenario functions with a single touch when required.

The one-touch scenario section has three default controls and they correlate with the control buttons on the remote controller. You can customize the content of each to fit your needs. After setup, the control buttons on the remote will carry out the same commands as the one-touch scenarios in the app.

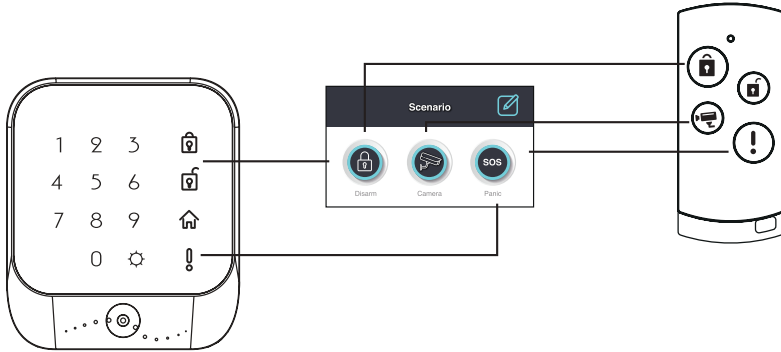

(A) ARM/PART-ARM/DISARM: Arm or Part-Arm preselected camera(s) and sensor(s). Select Disarm to disable system's Arm or Part-Arm status. Only after you have armed or part-armed the system, you will be able to receive Email/Push Notification (see System Setting/ for Notifications Setup details).

You will have 30 seconds to exit the premises after initiating the Arm or Part-Arm function.



(B) CAMERA: Activate selected camera(s) for sudden recording needs (apply to all and remote only).

(C) PANIC: Activate selected camera(s), siren(s) and Power Switch(es) for emergency recording, alarm sound and/or lighting needs.

By default, the kit sensors will appear in the control group list AFTER you paired the sensors to the Main Control Unit. Please follow the steps below to edit sensor list.



Additional Note on RF Keypad

You can control Arm/Part-Arm/Disarm Using RF Keypad to do so please follow instructions below to setup the RF Keypad.

1. First change the default RF Keypad password, to do so, tap  and enter default password "1234" (The RF Keypad will beep twice indicating password correct and re-enter default password if incorrect password entered).
2. Enter "1" following with your new four digits password (The RF Keypad will beep twice confirming input).
3. Tap  to save password setting.

Once the RF Keypad has been set, to ARM the system simply tap ARM or PART-ARM. To DISARM the system, tap DISARM once and enter the four digits password (The RF Keypad will beep twice indicating password correct and re-enter default password if incorrect password entered).



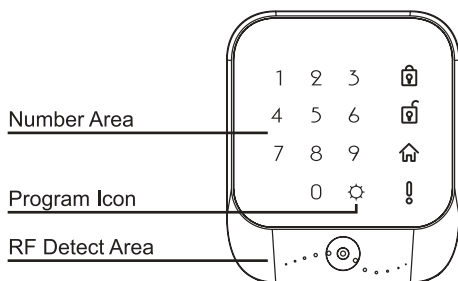

You can also use RF Tag(s) to disarm the system. Follow the instructions below to register RF Tag(s) with Keypad (it is recommend to first setup new password for the RF Keypad before attempting register RF Tag(s) with Keypad).

1. Tap  and enter the password (The RF Keypad will beep twice indicating password correct and once for incorrect password - re-enter default password if incorrect password entered).
2. Place the RF Tag (one at a time, maximum 8) to the RF detect area (The RF Keypad will beep twice indicating registration complete).
3. Tap  to save RF Tag pairing.
To unregister RF Tag(s) with Keypad, follow steps 1-3.



Setup the One-touch Scenario

To setup customized one-touch scenarios (ARM/Camera/Panic), please go to the Scenario section and follow the steps below:

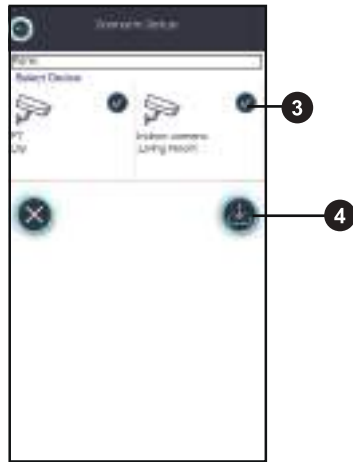
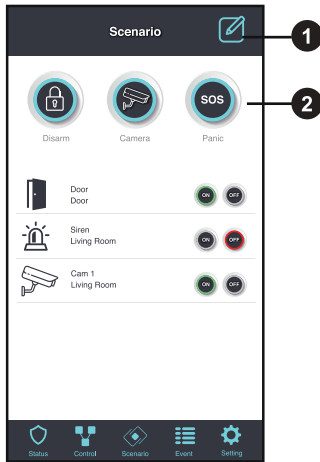

1. Tap  to activate the edit mode.
2. Tap  with one-touch scenario you wish to edit.
3. Rename the one-touch scenario if you wish to do so. Check and tick mark the items you wish to include for Arm/Part-Arm, Camera and Panic scenario. Only the items selected will be activated.
4. Tap  to complete setup or  to exit setup.



Sequence Scenario

Allowing the system to automatically react to the sudden situation and carry out other pre-defined tasks. For example, once the motion sensor detects motion, the camera will begin recording and the light turns on.

To setup the sequence scenario(s), please go to the Scenario section and follow the steps below:

1. Tap to select one of the **'initiator'** (When...) from the list (example: door/window sensor).
2. From the list, tap **+** to select the **'follow-upper'** (Then..., example: camera).
3. You can continue (tap **+**) to include more **'follow-upper'**. Tap  to complete the setup or  to exit setup.

With the example sequence scenario, once the door/window sensor(initiator) detects movement, the camera (follow-upper) will automatically begin recording, light turn on and the siren go off.

Enable for scenario to function properly, please make sure the sensor(s) in the list is activated (a). For camera, you would want to check mark the 'Record' so camera will record video and **'View'** for auto video screen popup (b). Without SD card inserted, you can only view but not record the video footage.

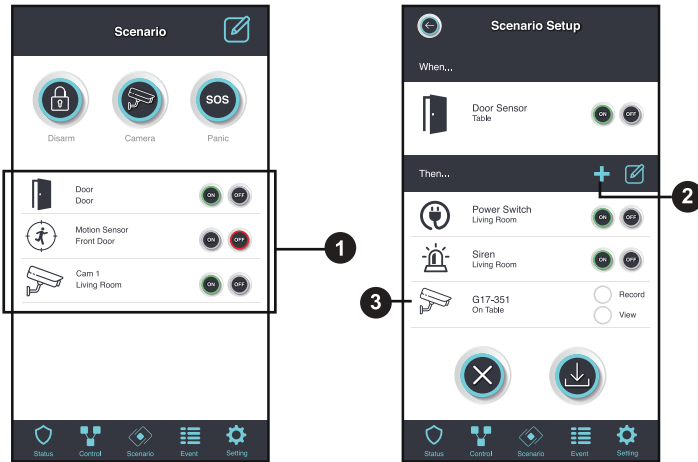

How to activate/deactivate the scenario:

Go to the Scenario setup page and tap on 'On' to activate the selected sequence scenario, or 'Off' to deactivate the selected sequence scenario.

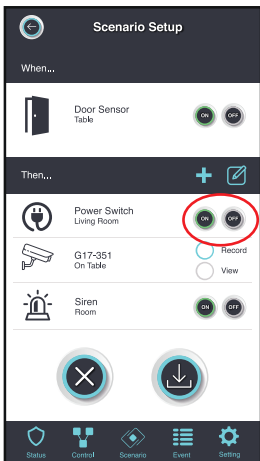

Note: System will take about 10 seconds to be fully ready to deploy the scenario application after activating the scenario.

Note: The system will not send out any Email Alert or Push Notification when Sequence Scenario is in action.

3. Event List



Event



All triggered events are recorded and displayed here in the 'Event' section. To identify exactly which sensor was triggered, including the time and the date. You can review recorded video file by tapping on the camera triggered event. You can also do in App event download by tapping the edit button on top right. Then tap the event or video you want to download. One download at a time.

4. Setting

The system setting contains various options allowing you to setup/configure the system details. The default admin password is '123456'.



Setting

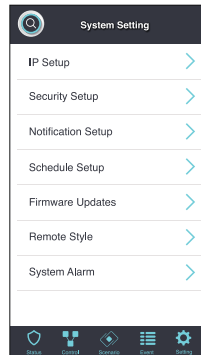
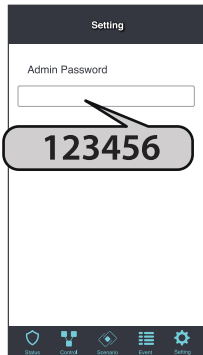

Note: Only the user who has the admin password can alter the Ximple W2 system settings. Please change the default password to your admin password immediately.

IP Setup

Setup the Internet protocol settings for the system. This tick DHCP and all will be done itself.

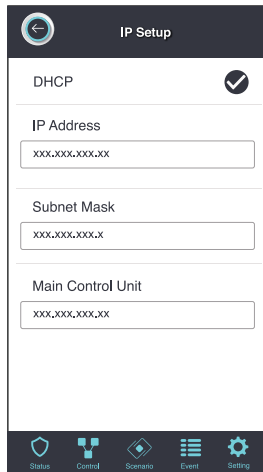

Security Setup

Here you can alter the system's default '**Security Code**' and '**Admin Password**'. Also you can enable/disable and setup the PIN Lock for the app. Once setup and enabled, you will need to enter the PIN Lock code everytime to enter the app.

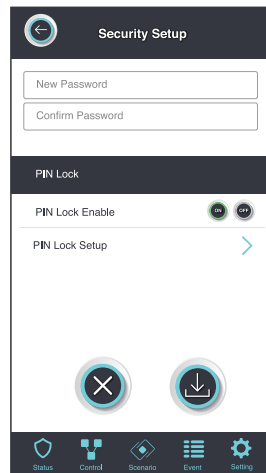
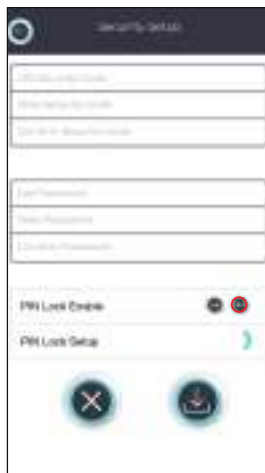

Notification Setup

Here you can turn On/Off the Email Alert and Push Notification. Enable for the Email Alert to function properly you will need to enter an effective email address.

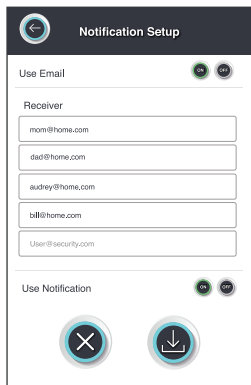

Both Email/Push Notification are available for system Arm, Disarm Part-Arm and trigger events generated from camera, motion sensor and door/window sensor selected in the ARM/PARTARM/DISARM scenario section.



Note : For IOS App,if you turn off the Notification Function here, you and others will not able to receive any push notification, even you have turned on the notification function in the fication section of the IOS System setting. For Android & IOS App, you must turn on the notification function. You and others are able to receive panic notification.

Schedule Setup

This is designed specifically for the power switch. After setup the selected power switch(es), they can turn on/off accordingly. Please follow the steps below to complete setup:

1. From the list, tap the switch you wish to setup.
2. Tap **+** to begin setup.
3. Tick the days.
4. Define '**start**' and '**end**' time.
5. Tap  to complete setup or  to exit setup.

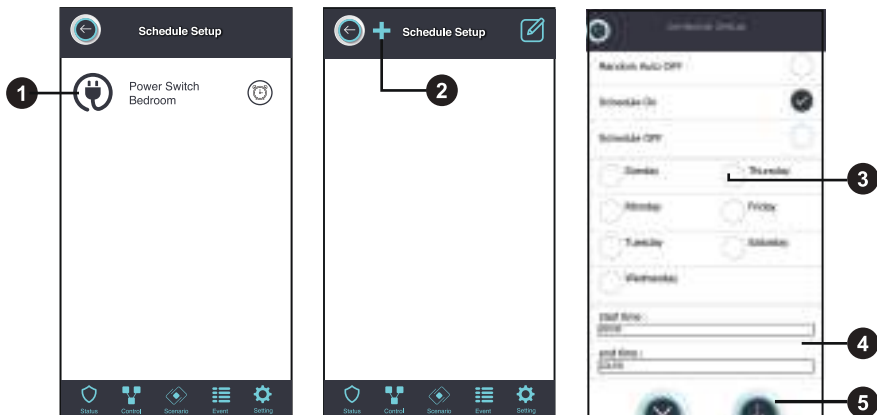

For Power Switch, you can also select Random On/Off. This is good for creating "someone is home" scenario to deter possible intruders.

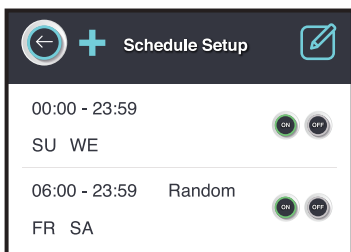

Note:

Since the system automatically synchronizes its clock with Network Time Protocol (NTP) via internet therefore the Ximple W2 schedule setup will not operate normally if the system is not connected to the internet.

Network Time Protocol (NTP) is a networking protocol for clock synchronization between computer systems over packet-switched, variable-latency data networks.

Firmware Updates

Here you can check to see if any new updates are available. To begin, tap on 'Download' and if new update is available, popup screen will ask you if you wish to proceed, select 'Yes' and the app will automatically download and install the new update. The Main Control Unit will then auto-reboot and beep twice when done.

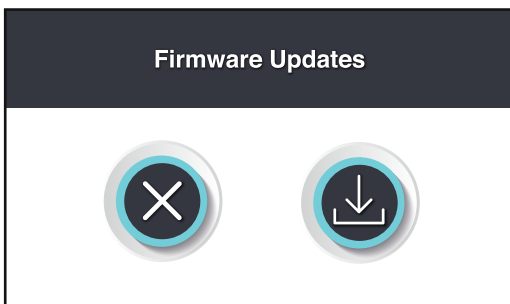

Note: Please do not shut off the Main Control Unit or unplug the Ethernet cable connected to the Main Control Unit during the update.

Remote Style

The **'Remote Control'** mode is designed for easy operation. The control functions are the same as the **'One-touch Scenario'** and the remote controller.

Once you activate the function, next time you launch the app the screen will only display the **'Remote Control'**. To deactivate, go to system setting and deactivate the function in the **'Remote Style'** section.

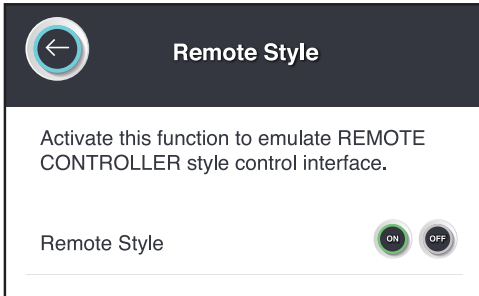

Advance Control

Here you can turn on the **'Zone'** function. This function is for advanced user only. The **'Zone'** function can control camera(s), power switch(es) and can be activated/deactivated with one single touch. You can have up to 9 Zone controls, with each customized to fit your needs. To activate the **'Zone'** function, please follow the steps below:

1. Go to System Setting, in the **'Advance Control'** section, turn on the **'Advance Control'**.
2. The **'Zone'** control function will appear at the bottom navigation section after exiting System Setting.

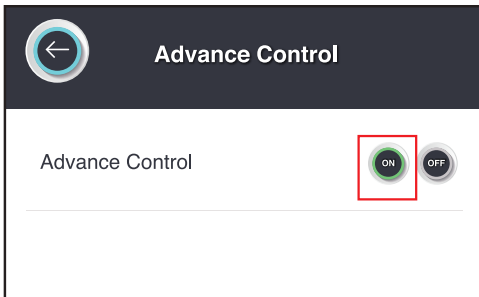

To setup the 'Zone' control, please go to 'Zone' section follow the steps below to complete the setup.

1. Tap **+** to begin.
2. You can personalize the Zone name.
3. Tick the camera(s) and/or power switch(es) you wish to include for control.
4. Tap **↓** to complete the setup or **×** to exit setup.



About

You can find here the system ID (DID), firmware and APP information. You will need these info for technical support.

ADDITIONAL USEFUL FEATURE

Using the Power Switch as Repeater - Repeater Setup

To Activate the Repeater Function of your Power Switch

First make sure the Power Switch and the end Sensor has been successfully paired/connected to the system Main Control Unit. See "Sensor Pairing" section for more details.

Step 1

Press/hold the button located on the front of the Power Switch until the LED begins to flash in blue and orange.

Step 2

While the LED on Power Switch is flashing blue and orange, activate the pairing mechanism on the end Sensor. The LED on Power Switch will turn steady orange indicating the repeater pairing process has complete.

Note:

You will not be able to control the end Sensor if the Power Switch (repeater) is unplugged. Reinststate the Power Switch to regain the control and communication between Main Control Unit and end sensor.

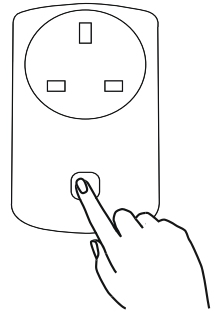

To Deactivate the Repeater Mode

1. Unplug the repeater Power Switch.
2. Press and hold the button in front of the Power Switch and plug the Power Switch back to the outlet with the button pressed, do not let go of the button until the LED begins to flash (blue).

The LED indicator on the original repeater Power Switch now should light up in blue, indicating the repeater function has been deactivated.

Both Power Switch and the end sensor will require re-pairing with Main Contol Unit to resume their normal operation. Please see 'Sensor Pairing' section for more details.

TROUBLESHOOTING

Problem	Possible Cause / Possible Solution
The Main Control Unit is not working	<ul style="list-style-type: none">- Check the AC power adapter. Make sure it is correctly plugged.- Check the Ethernet cable. Make sure the connector is plugged in the Ethernet socket and the other end plugged into the router.
The sensor is not functioning	<ul style="list-style-type: none">- Check the battery polarity and make sure the battery has enough power to function correctly. Replace the batteries if necessary.- Make sure the Main Control Unit is powered on. As a control center of the system, it should be left powered on all the time.- Sensor malfunction. Pair the sensor to Main Control Unit again.
Low Battery	<ul style="list-style-type: none">- The batteries that power the sensor is in low-power status. Replace the batteries for the sensor(s).
Cannot remotely connect to the system from mobile device	<ul style="list-style-type: none">- Check the Internet status LED above the Ethernet cable. The orange LED indicates the network socket is powered on. The green LED indicates the network status. <p>If the Green LED becomes STEADY GREEN instead of flashing, it means the network fails. Please make sure the router is functioning well, re-connect the Ethernet cable and power on the Main Control Unit again.</p>
What should I do if I forgot the password or network configuration setting?	<ul style="list-style-type: none">- Press the Reset button (located beside the power socket).

FREQUENTLY ASKED QUESTION

Why Home/Office Security?

- It is better to be safe than sorry, as burglary happens more often than you think. More than 20,000 burglaries are reported in the Malaysia EACH year .
- Thanks to the advanced modern technologies, finding an effective and affordable security system is now easier than ever and is not just for the privileged anymore.

Why Ximple W2 is more advanced than other app-based Smart Home system?

- Ximple W2 is SECURITY focused with elements of smart home – Smart home isn't so smart if cannot protect people and valuables.
- Every part of Ximple W2 is designed, developed by Archtron R&D Sdn. Bhd. All the devices of Ximple W2 are compatible with each other and the system is secured with minimum concerns for security breach.
- Ximple W2 is field proven, millions of users is using Archtron Research & Development security/surveillance system daily for protection. The system is stable and reliable.
- Price point is important and Ximple W2 is geared for flexible configurations, from starter kit to big-box packaging, fit for various type of channels.
- No contracts, no recurring monthly fees.
- The system is wireless so no damages to existing structure.
- Wide coverage, from security and surveillance to safety and family care.
- Truly designed for consumers. The system is ready for operation minutes after opening the box – Plug-n-Protect!
- Archtron Research & Development offers one-stop-shopping and services since everything is designed and developed in-house.
- Bandwidth friendly, the system require minimum internet bandwidth to operate.
- Quality and consistency – Ximple W2 is designed in Malaysia using the latest technologies.
- User can create own unique scenarios to counter any situation.
- Compatible with various type of in-house cameras for any type of visual verification requirement.
- Ximple W2 uses proprietary P2P technology to maximize privacy management.

The system is extendable?

- Absolutely – Ximple W2 supports up to 4 indoor/outdoor cameras (can be installed anywhere in the world) and 24 sub-devices (sensor).
- The Ximple W2 app works with multiple Main Control Unit (up to 8) so user can manage different locations using one single app – anytime, anywhere.

Any benefits from using P2P service, why not cloud-based?

- No extra cost for the cloud service, only the existing internet service.
- All the data (video event, snapshots, trigger records, etc.) are kept locally and only the owner can access those information, privacy concerns are minimum.
- Owner can have access to all the data even when internet is down.

The Main Control Unit is not responding?

- First check to the status of LED's and refer to the user manual for what each represents/indicate.
- If non of the LED's are on, check the AC power adaptor to make sure it is plugged in securely.
- Check the Ethernet cable to make sure the connector is plugged in at both ends, at the Main Control Unit Ethernet socket and the LAN port on the router.
- Check the router to make sure it is powered on and functioning, also check its Ethernet/coaxial cable make sure it is securely plugged in.
- User may need to restart the router to secure the internet connection. Contact internet service provide for assistance.
- Check to see the smartphone/tablet is connected with internet.

The Ximple W2 sensor is not functioning.

- Check the battery is inserted correctly with the correct polarity as indicated.
- Check to see if the battery power is low. The Ximple W2 app will inform user if the battery power is low. Replace battery if necessary.
- Make sure the Main Control Unit is powered on and its Ethernet cable plugged in securely. The Main Control Unit manages all sensors and it should be powered on at all time.
- Reset the sensor if necessary and pair the sensor to the Main Control Unit again.

When should the batteries of the sensor need to be changed?

- When app is indicating the battery power is low in the sensor(s). Under normal circumstance the app will indicate low battery information 15 days before the battery depletes completely.
- Under normal usage, most of the batteries should last at least 1~2 years due to Ximple W2 advanced power consumption management technology.

My smartphone/tablet (iOS/Android) cannot remotely connect to Ximple W2.

- Check to see if the smartphone/tablet is connected with internet. Activate the connection if is set to off.
- Check to see if the “airplane mode” is on, switch it off to resume internet connection.
- Check to see if the internet connection is busy by using “Speed Test” app or website offering the service.
- If none of the above works, please reset the Main Control Unit by press and hold the reset button located at the back of the Main Control Unit for 5 seconds. Do remember to add the Main Control Unit back to the app afterwards.
- For privacy concern, the system settings/password are not stored anywhere. After resetting the Main Control Unit everything goes back to original default value, including Security Code. Make sure to inform family members the new password.

What is the benefit of the remote controller?

- Excellent for elders and children, who do not have access to smartphone/tablet.
- Quick system ARM/DISARM without any smartphone/tablet.
- Activate camera recording function with a single push.
- Activate panic function with a single push and hold for 5 seconds.
- Ximple W2 app installed will receive push notification and if indoor/outdoor siren is part of the system it will go off for 3 minutes as well.

Where can Ximple W2 Secure Home Control be installed?

- Residential
- Small business
- Office
- Condominium
- Double Storey
- Shop Lot
- Apartment

I just got a new phone/tablet.

- First delete the Ximple W2 app from the old phone. Go to App Store or Google Play to download the Ximple W2 app to the new phone/tablet, re-install the Main Control Unit to the app and all previous settings will remain.

Why must I change the factory default security code/password?

- Although it is still difficult for others to access your system, but it is better to be safe than sorry. Having unique security code/password can only strengthen the privacy protection.
- After establishing new and unique security code/password, please keep the information at a safe place so you won't have to RESET the system and reconfigure everything all over again.

The IP camera came with Ethernet cable, does that mean I cannot go wireless?

- Absolutely not, just follow the installation guide (Quick Start Guide / User Manual) for wireless connection.
- The Ethernet cable came with the camera is there for setup convenience only, as some installation locations may have unstable internet connection, which the cable will make things easier for the user to setup the camera for the first time.

Why do I need the siren?

- The siren, either the indoor or the outdoor version can be extremely effective for scaring off the intruder – at the moment of the break-in. Without siren the intruder may further cause damages and additional valuables may be lost.
- The siren isn't there only to scare off the intruder, you can easily setup to have the siren to go off when children attempt leaving the house when they are not suppose to.
- The outdoor siren is very important as well since you may be in the backyard when something happens inside the house. Your neighbor may notice the alarming siren and contact you, police or fire station as well if you are not at home.

Why do I need the Power Switch?

- Similar to the effect of the indoor/outdoor siren, the Power Switch can activate lights at the moment of the break-in. With the lights turned on many times the intruder may likely choose to scape.
- You can setup to have the Power Switch to turn lights on/off at certain times even when you are not there, so others may think twice about breaking in.
- The power switch can be for your convenience also, where you can manually control lighting devices without getting up off the bed. Further, other Ximple W2 devices can trigger off the power switch as well, besides having the lights turn on automatically when walk into the room because the PIR sensing your presence, you can also use it to turn on fans, radio, home appliances such as space heater, cooker, coffee machine, dehumidifier, etc.
- The power switch can double as Ximple W2 signal repeater as well, making the system to work even more efficiently and effectively.

Why do I need the door/window Sensor?

- The Ximple W2 door/window sensor can alert you locally (via siren, light, etc.) or remotely via push notifications and app's real-time device status indicator that someone (even toddlers, pets, etc.) opens the door or window.
- The Sensor can further setoff other devices to react to the event, such as activate the recording function of the camera, have power switch to turn on the light, etc.
- The door/window Sensor is completely wireless so you can also be installed to cabinet doors, desk drawers, safe, or even objects such as portable DVD player so if someone picks up the player you will know immediately.

Why do I need the PIR motion detector?

- The PIR motion detector can detect unwanted presence and set off alarm, trigger power switch, activate camera recording function and alert user via push notifications.
- The PIR motion detector can also be used as convenience purpose as well, such as automatically turn on lights and fans via power switch.
- Once the PIR motion detector has been triggered AND no longer senses motion, it will dormant for two minutes to conserve its battery power, otherwise the PIR will stay awake and continue to send off alert signal to the Main Control Unit and other Ximple W2 devices.

Why event list is informative and helpful?

- The event list contains every triggered events as record, including video events, so not only you can tell exactly when something took place, you can also playback the video events as well.
- Since all the events listing are in time sequence therefore you can identify the path of intruder, which may come in handy for police to solve the incidence.

How can I backup the recorded videos?

- You can backup the data off the memory card inserted in the camera (first unplug the camera to prevent damaging the memory card) to computer, and later view by using VLC player, which is a freeware you can find online.
- Another way is to download the video(s) to your smartphone/tablet by holding down the video event for few seconds and the app will prompt by asking you if download is needed, tap YES to download and save the file for later viewing.

Why do I need to use Class 10 rated memory card for the network camera?

- The Ximple W2 camera is capable of recording high definition resolution videos therefore Class 10 rated memory is suggested due to the large video data.
- Class 10 memory card can be easily accessed at local electronic stores or be purchased online for very low cost.

I am not receiving push notifications.

- Please make sure the app's notification function on your smartphone/tablet is activated. For iOS is the notification center and for Android system would be the "Information" section of the Ximple W2 app.

What is the difference between the Security Code and the Admin password?

- The Security Code is required for remotely accessing the Main Control Unit and camera. For maximum security purpose, the Ximple W2 Main Control Unit and its every cameras can have individually unique different Security Codes. Only the person who has the Security Code(s) can access, operate, control and view Main Control Unit and cameras.
- The Admin password is required to access Ximple W2 Main Control Unit and cameras' Advance Setting section. For maximum security purpose, the Ximple W2 Main Control Unit and its every cameras can have individually unique different Admin password. Only the person obtaining the password(s) can access and alter the settings of Main Control Unit and cameras.

What benefits are offered by the Pan/Tilt/Zoom network camera?

- Besides streaming/record video data, two-way audio, night view, snapshots, you can also control the camera angle (0°~350° horizontal / -10°~80° vertical), you can define up to three preset view angles for one-touch (no swiping control action required) control.
- Further you can setup to have certain sensor(s) to trigger any of the three preset view angles to automatically direct the view angle towards the sensor location for precise view/record.

Besides for residential protection, Why Ximple W2 also fit small business/office?

- Most of the small business/office has limited budget therefore Ximple W2 not only can save installation costs/labor, owner won't have to deal with recurring monthly fees and penalty cost due to false alarms.
- Owner of small business/office can start small and build up the system whenever needed.

Why is there always a "clicking" sound from the network camera when light goes on/off?

- That is perfectly normal. The "clicking" sound is made by the camera's IR-cut Switcher switching to suitable lens filter for better viewing performance.

What is the minimum system requirement for the Ximple W2 app?

- iOS 8.0 or above.
- Android 4.2.X or above.

What is the difference between system ARM and Partial ARM?

- The system ARM is for arming the entire system (entire house) and partial ARM is for arming some of the Ximple W2 devices (1st floor only), which is good for night time when owner can still freely move about in the bedroom and upstairs hallway, etc.

Can I install the four network cameras in different locations?

- Absolutely yes. The cameras can be located in different countries even and still be accessed/monitored via single app, just add the DID/Security Code of the individual camera to the app. Video events of different cameras can still be listed in the event list in time sequence despite of the time zone difference.

PRODUCT SPECIFICATION

Main Control Unit

Model Number	BLU - XIM - MCU02
Operation Voltage	DC 12V/1A
Ethernet	10/100Mbps
Sub-1G	868.3 (EU) Mhz
LED Light	Max Standby 8hr
User Macro	Sensor/Power
	APP

Indoor Siren

Model Number	BLU - XIM - IS02
Signal Frequency	868.3 (EU) MHz
RF Range (open field conditions)	150M
Power Source	DC-in 5V/1A (4 x AA batteries as backup power, not included)
Battery Life	Anticipated life up to 2 years (Supposed 10 triggers per day)
Piezo Siren	Maximum 110dB
Waterproof	IP44
Battery Power Monitoring	Yes (On device and transmitted to APP)
Tamper Detection	No
Tamper Switch	No
Operating Environment	Indoor
Operating Temperature	-10°~+50°C
Operating Humidity	10%~80%RH
Dimensions	120mm (H) x 80mm (W) x 35mm (D)

Remote Keychain

Model Number	BLU - XIM - KC02
Signal Frequency	868.3 (EU) MHz
RF Range (open field conditions)	150M
Battery Type	1 x CR2032 Battery (included)
Battery Life	Anticipated life up to 2 years (Supposed 10 triggers per day)
Battery Power Monitoring	Yes (On device and transmitted to APP)
Operating Temperature	0°~40°C
Operating Humidity	10%~80%RH
Dimensions	60mm (H) x 30mm (W) x 14mm (D)

Wireless Camera

Model Number	BLU - XIM - CAMD02
Wireless Compatible	IEEE 802.11 b/g/n
Sensor	Mega Pixel CMOS
Frequency	2400MHz~2485MHz
Protocol	TCP/IP, UDP, SMTP, NTP, DHCP, ARP
Image Compression	H.264
Image Resolution	HD 1280 x 720
Operating Temperature	-10°~+50°C
Operating Humidity	20~80 RH (N.A.-condensing)

Motion PIR

Model Number	BLU - XIM - PIR02
Signal Frequency	868.3 (EU) MHz
RF Range (open field conditions)	150M
Max. Detection Range	16M
Detection Angle	110°
Battery Type	3 x 1.5V AA Batteries (included)
Battery Life	Anticipated life up to 2 years (Supposed 200 triggers per day)
Battery Power Monitoring	Yes(On device and transmitted to APP)
Tamper Detection	Yes (Rear)
Operating Temperature	0°~40°C
Operating Humidity	10%~80%RH
Dimensions	110mm (H) x 61.4mm (W) x 51.6mm (D)

Door/Window Sensor

Model Number	BLU - XIM - TXD02
Signal Frequency	868.3 (EU) MHz
RF Range (open field conditions)	150M
Battery Type	1 x CR2032 Battery (included)
Battery Life	Anticipated life up to 2 years (Supposed 10 triggers per day)
Battery Power Monitoring	Yes (On device and transmitted to APP)
Tamper Detection	Yes (Front)
Operating Temperature	0°~40°C
Operating Humidity	10%~80%RH
Dimensions	Large piece: 71mm (H) x 27mm (W) x 14mm (D) Small piece: 71mm (H) x 13mm (W) x 13mm (D)

Power Switch

Model Number	BLU - XIM - PS02
Signal Frequency	868.3 (EU) MHz
RF Range (open field conditions)	150M
Plug Type	UK
Load Switching Capability	UK/2990W
Battery Power Monitoring	No
Operating Temperature	0°~40°C
Operating Humidity	10%~80%RH
Dimensions	94mm (H) x 55mm (W) x 31mm (D)

Smoke Sensor

Model Number	BLU - XIM - SD02
Signal Frequency	868.3 (EU) MHz
RF Range (open field conditions)	150M
Battery Type	2 x AA Alkaline Battery (included)
Battery Life	Anticipated life up to 1 year (standby mode)
Piezo Siren	85dB
Smoke Chamber	Photoelectric
Tamper Detection	Yes (Front)
Operating Temperature	0°~40°C
Operating Humidity	10%~80%RH
Dimensions	120mm (H) x 120mm (W) x 35mm (D)

RF Keypad

Model Number	BLU - XIM - KP02
Signal Frequency	868.3 (EU) MHz
RF Range (open field conditions)	150M
Battery Type	4 x AA Alkaline Battery (included)
Battery Life	Anticipated life up to 6 months (Supposed 3 entries/exits per day)
Battery Power Monitoring	Yes (On device and transmitted to APP)
Operating Temperature	0°~40°C
Operating Humidity	10%~80%RH
Dimensions	140mm (H) x 120mm (W) x 30mm (D)

Outdoor Siren

Model Number	BLU - XIM - OS02
Signal Frequency	868.3 (EU) MHz
RF Range (open field conditions)	150M
Power Source	4 x D-Type Battery (included) or 5V/1.5A Power Adaptor (optional, not included)
Battery Life	Anticipated life up to 18 months (Supposed 1 trigger per month, each time 3 minutes))
Piezo Siren	Maximum 105dB
Waterproof	IP44
Battery Power Monitoring	Yes (On device and transmitted to APP)
Tamper Detection	Yes, device alert sound and alert indicator on app
Tamper Switch	Yes
Operating Environment	Outdoor
Operating Temperature	-10°~+50°C
Operating Humidity	10%~80%RH
Dimensions	245mm (H) x 130mm (W) x 95mm (D)